

FRENTE MOSTRADOR  
SNACK  
PAG-24-25  
**FMRP**

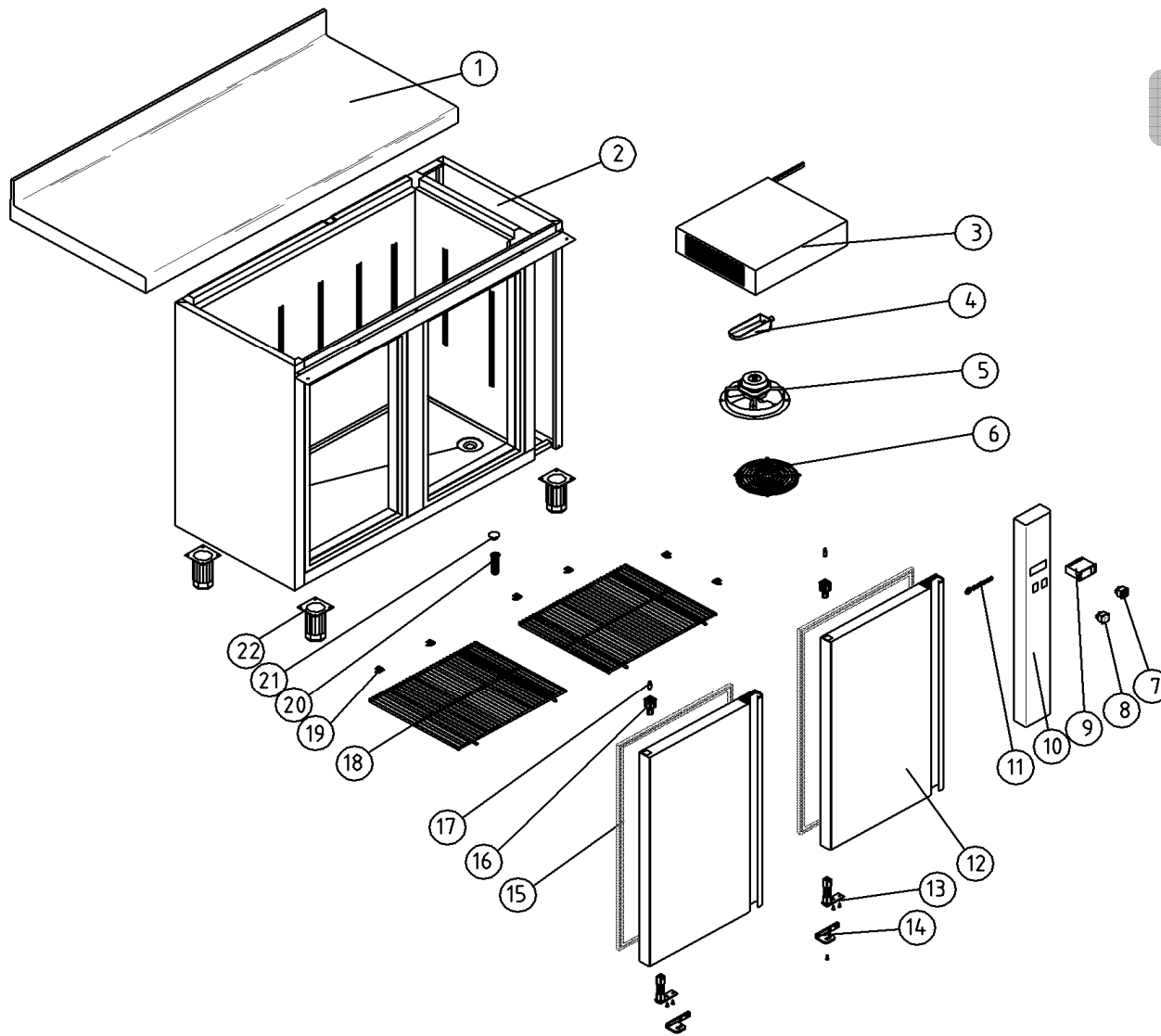

Nº	DESCRIPCIÓN	DESCRIPTION	FMRP-120	FMRP-170	FMRP-220	FMRP-270
1	ENCIMERA	WORKTOP	M181010405	M181010406	M181010407	M181010408
2	COSTADO EXTERIOR DCH.	RIGHT EXTERNAL SIDE	M161290012	M161290012	M161290012	M161290012
3	EVAPORADOR	EVAPORATOR	6029010143	6029010143	6029010140	6029010140
4	DESAGÜE CANALIZADOR	DRAIN CANAL	6003010184	6003010184	6003010184	6003010184
5	VENTILADOR EVAPORADOR	EVAPORATOR FAN	6021050072	6021050072	6021050072	6021050072
6	REJILLA PROTECCION VENT.	FAN PROTECTION GRILLE	6003010475	6003010475	6003010475	6003010475
7	PILOTO ROJO	RED PILOT	6021130013	6021130013	6021130013	6021130013
8	INTERRUPTOR GENERAL	MAIN SWICHT	6021130011	6021130011	6021130011	6021130011
9	TERMOSTATO	THERMOSTAT	6021350097	6021350097	6021350097	6021350097
10	CUADRO DE MANDOS	CONTROL PANEL	M109010654	M109010654	M109010654	M109010654
11	LOGOTIPO	LOGOTYPE	6023010551	6023010551	6023010551	6023010551
12	PUERTA 826 x 510 mm	DOOR 826 x 510 mm	M169010086	M169010086	M169010086	M169010086

Nº	DESCRIPCIÓN	DESCRIPTION	FMRP-120	FMRP-170	FMRP-220	FMRP-270
13	BISAGRA	HINGE	6033010100	6033010100	6033010100	6033010100
14	SOPOORTE BISAGRA	HINGE SUPPORT	6033010098	6033010098	6033010098	6033010098
15	BURLETE 460 x 775 mm	SEAL 460 x 775 mm	6045010124	6045010124	6045010124	6045010124
16	CAJA ALOJAMIENTO EJE	HINGE PIN SUPPORT	6003010136	6003010136	6003010136	6003010136
17	EJE PUERTA	SPLINDE DOOR	6033090064	6033090064	6033090064	6033090064
18	ESTANTE EXTREMOS	LATERAL SHELF	6027010079	6027010079	6027010079	6027010079
18	ESTANTE CENTRAL	CENTRAL SHELF		6027010078	6027010078	6027010078
19	SOPORTE ESTANTE	SHELF SUPPORT	6033210007	6033210007	6033210007	6033210007
20	DESAGÜE 3/4	DRAIN PIPE 3/4	6003010326	6003010326	6003010326	6003010326
21	TAPON DESAGÜE 3/4	DRAIN CAP 3/4	6003010262	6003010262	6003010262	6003010262
22	PATA REGULABLE	ADJUSTABLE FEET	6007050017	6007050017	6007050017	6007050017
23						