

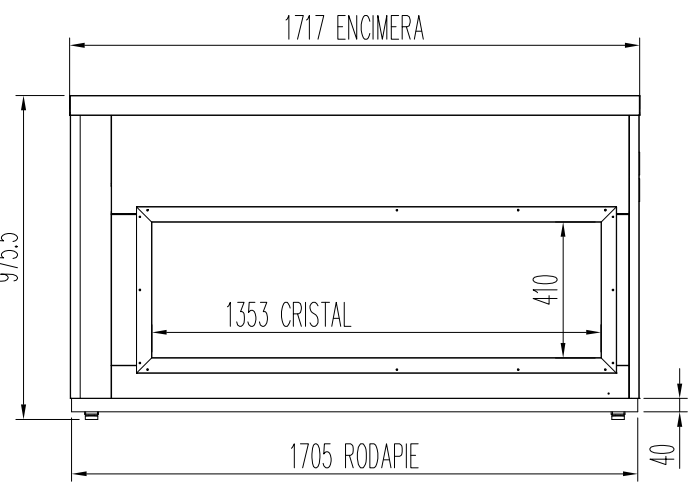

REFUERZO FONDO 380  
REFUERZO FONDO 525

RESPALDO VENTANA DE CRISTAL  
PARA MODELOS  
BVP,EBPV-170



ENFRIADOR DE BARRILES PRE-INSTALACIÓN					COD. PIEZA: X													
COTAS SIN TOLERANCIA DIN 7168-f					Material: .													
					Acabado: .													
ANGULAR	GRADO TOLERANCIA	FINO	MEDIO	GRUESO	COMUN A	MODELO	Ud.	MODELO	Ud.	MODELO	Ud.	MODELO	Ud.	MODELO	Ud.			
	HASTA 10 mm		±1°			±1° 30'	EBP-170	1										
	MAS DE 10 A 50 mm		±30'			±50'	EBVP-170	1										
	MAS DE 50 A 120 mm		±20'			±25'												
MAS DE 120 A 400 mm		±10'		±15'														
MAS DE 400 mm		±5'		±10'														
LINEAL	GRADO TOLERANCIA	FINO	MEDIO	GRUESO	A4	Nombre		Fecha										
	HASTA 3 mm		±0,05	±0,10		±0,15	Dibujado		17-10-12									
	MAS DE 3 A 6 mm		±0,05	±0,10		±0,20	Modificado											
	MAS DE 6 A 30 mm		±0,10	±0,20		±0,50	Escala											
	MAS DE 30 A 120 mm		±0,15	±0,30		±0,80	<b>VISTAS MEDIDAS GENERALES EBP-170</b> <b>EQUIPOS PRE-INSTALACIÓN</b>											
	MAS DE 120 A 400 mm		±0,20	±0,50		±1,20							Código máquina: <b>CODIGO</b>					
	MAS DE 400 A 1000 mm		±0,30	±0,80		±2,00												
	MAS DE 1000 A 2000 mm		±0,50	±1,20		±3,00												