

ASC-ES-1303

ARMARIO SNACK CURACIÓN Y SECADO DE CHARCUTERÍA

CARACTERÍSTICAS

- Exterior en acero inoxidable AISI-304.
- Respaldo en chapa de acero galvanizado.
- Interior en acero inoxidable AISI-304, con aristas curvas y fondo embutido.
- Puertas de apertura reversible, con sistema de cierre automático y burlete magnético (permanece abierta al superar los 90° de apertura).
- Contrapuerta inox embutida.
- Luz interior LED.
- Dos recintos independientes, una para estufaje y otro para secado.
- Barras carniceras (3 barras por cada Kit).
- Pies en tubo de acero inox ajustables en altura 135 - 210 mm.
- Cuadro de mandos y rejilla ventilación motor desmontables.
- Unidad condensadora ventilada.
- Resistencias para ciclos que requieran subir la temperatura.
- Ventiladores con funcionamiento independiente frío – calor – humedad.
- Evaporador sistema tiro forzado, con recubrimiento epoxi anticorrosión.
- Paro ventiladores tiro forzado al abrir la puerta.
- Evaporación automática del agua de descarche.
- Aislamiento de poliuretano inyectado, densidad 40 kg/m³,cero efectos ODP y GWP.
- Control digital de temperatura, descarches optimizados, alarma por alta temperatura de condensación. Eficiente gestión del consumo de energía.
- 6 programas de ciclos programables.



Largo (mm)	Fondo (mm)	Alto (mm)	Capacidad (L)	Potencia frigorífica (W)	Estufaje (W)	Secado (W)	Rango	Clase climática	Refrigerante
1370	745	2155 - 2230	1201	750	556	360	+4°C +30°C	5 (40°C 40%HR)	R290

Características técnicas y constructivas sujetas a variación sin previo aviso, todas las fotos deben ser consideradas como una referencia

ASC-ES-1303

ARMARIO SNACK CURACIÓN Y SECADO DE CHARCUTERÍA

Control de temperatura	Digital
Evaporador	Bloque aleteado epoxi
Condensador	Bloque aleteado
Voltaje / Frecuencia	230V 50Hz
Aislante térmico	Poliuretano, densidad 40 kg/m ³ , cero ODP y GWP
Agente espumante	HFO
Espesor aislante costado	70 mm
Exterior	AISI-304 acero inoxidable
Respaldo exterior	Acero galvanizado
Interior	AISI-304 acero inoxidable
Luz	Led
Barras carniceras	5 kits

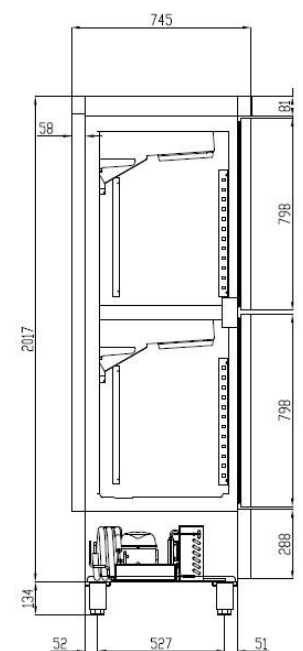
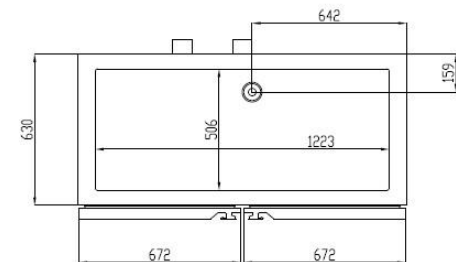
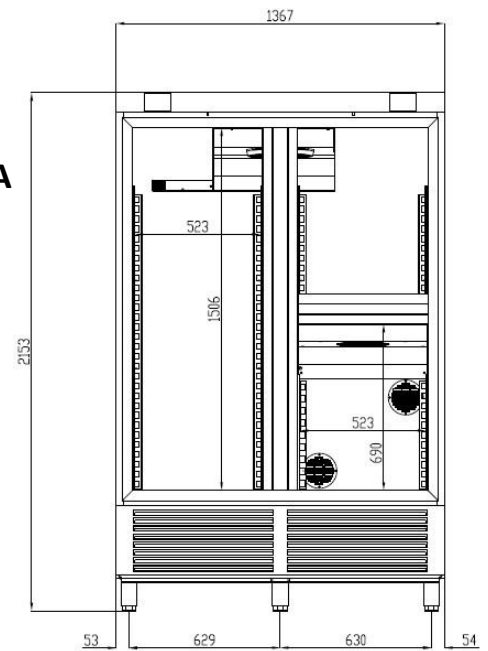

Características técnicas y constructivas sujetas a variación sin previo aviso, todas las fotos deben ser consideradas como una referencia

ASC-ES-1303

SNACK CABINET FOR CHARCUTERIE

FEATURES

- AISI-304 stainless steel exterior.
- Rear side in galvanized panel.
- AISI-304 stainless steel interior, stamped bottom and rounded corners.
- Doors with self closing system, blocked opening, magnetic gasket possibility of changing the opening sense.
- Inner side of doors by stamped steel.
- LED lighting.
- Two independent sections, one for dripping and one for drying.
- Meat bars (3 for each kit).
- AISI-304 adjustable legs, 135 to 210 mm.
- Removable control panel and motor ventilation grille.
- Ventilated condensing unit.
- Resistances for cycles that require raising the temperature.
- Fans independent operation cold – heat – humidity.
- Evaporator forced draft system, with anti-corrosion epoxy coating.
- Forced draft fans stop when the door is opened.
- Automatic evaporation of defrost water.
- 40 Kg/m³ density polyurethane insulation, zero ODP and GWP.
- Digital temperature control, optimized defrost, high-temperature condensation alarm. Efficient management of energy consumption.
- 6 programmable cycle programs.



Lenght (mm)	Depth (mm)	Height (mm)	Capacity (L)	Cooling power (W)	Dripping (W)	Drying (W)	Range	Climatic class	Coolant
1370	745	2155 - 2230	1201	750	556	360	+4°C +30°C	5 (40°C 40%HR)	R290

We reserve the right to change specifications without prior notice, all photos must be considered as a reference



ASC-ES-1303

SNACK CABINET FOR CHARCUTERIE

Temperature control	Digital
Evaporator	Epoxy finned block
Condenser	Finned block
Voltage	230V 50Hz
Insulation material	Polyurethane, 40 kg/m ³ density, zero ODP and GWP
Foaming agent	HFO
Insulation thickness side	70 mm
Exterior	AISI-304 stainless steel
Exterior rear side	Galvanized steel
Interior	AISI-304 stainless steel
Lighting	Led
Butcher bars	5 kits

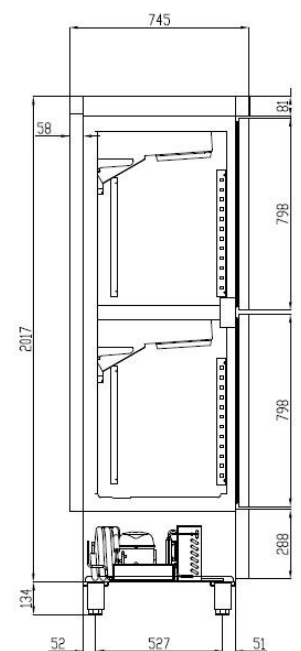
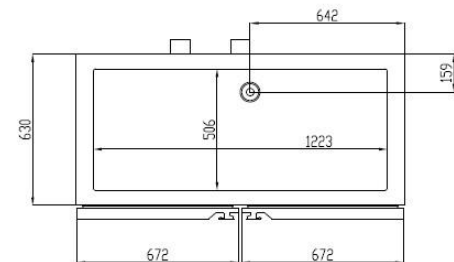
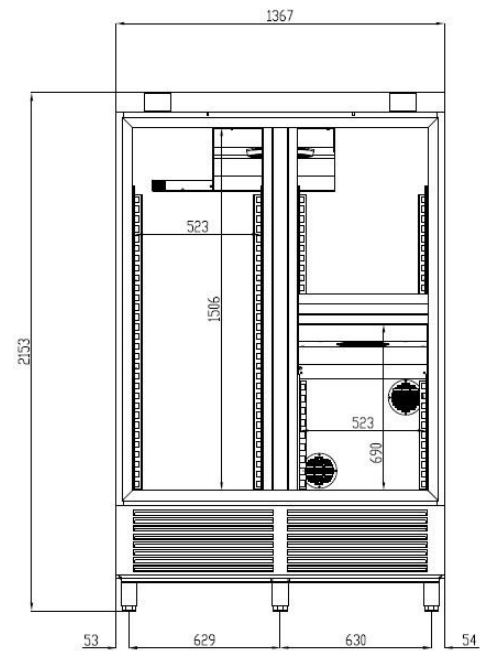

We reserve the right to change specifications without prior notice, all photos must be considered as a reference