

FONDO PARA PLATOS

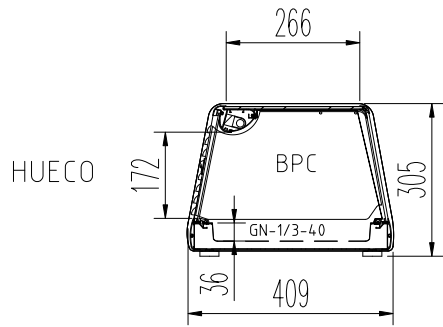

FONDO PARA CUBETAS GN-1/3-40mm

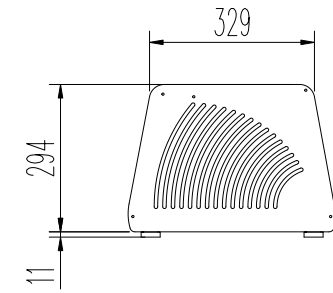
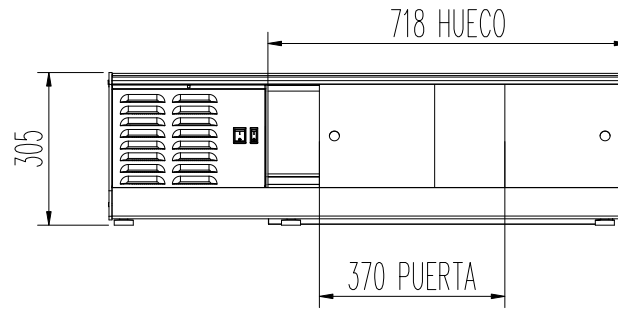

LADO GRUPO

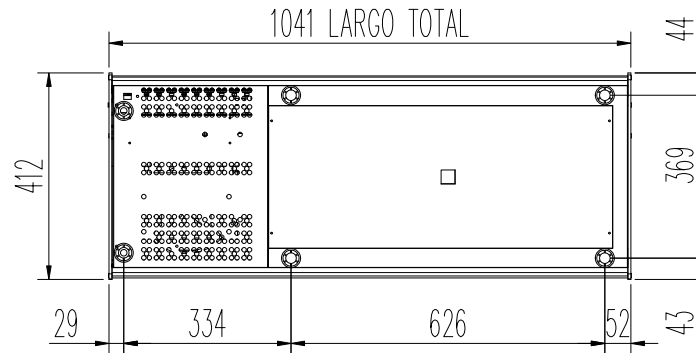

V1 VITRINA BANDEJA FRIA							COD. PIEZA: X																																																									
COTAS SIN TOLERANCIA DIN 7168-f							Material: MATERIAL ESPESOR																																																									
<table border="1"> <thead> <tr> <th>GRADO TOLERANCIA</th> <th>FINO</th> <th>MEDIO</th> <th>GRUESO</th> </tr> </thead> <tbody> <tr> <td>HASTA 10 mm</td> <td>±1'</td> <td></td> <td>±1° 30'</td> </tr> <tr> <td>MAS DE 10 A 50 mm</td> <td>±30'</td> <td></td> <td>±50'</td> </tr> <tr> <td>MAS DE 50 A 120 mm</td> <td>±20'</td> <td></td> <td>±25'</td> </tr> <tr> <td>MAS DE 120 A 400 mm</td> <td>±10'</td> <td></td> <td>±15'</td> </tr> <tr> <td>MAS DE 400 mm</td> <td>±5'</td> <td></td> <td>±10'</td> </tr> </tbody> </table>							GRADO TOLERANCIA	FINO	MEDIO	GRUESO	HASTA 10 mm	±1'		±1° 30'	MAS DE 10 A 50 mm	±30'		±50'	MAS DE 50 A 120 mm	±20'		±25'	MAS DE 120 A 400 mm	±10'		±15'	MAS DE 400 mm	±5'		±10'	Acabado: ACABADO				SUSTITUYE A:																													
GRADO TOLERANCIA	FINO	MEDIO	GRUESO																																																													
HASTA 10 mm	±1'		±1° 30'																																																													
MAS DE 10 A 50 mm	±30'		±50'																																																													
MAS DE 50 A 120 mm	±20'		±25'																																																													
MAS DE 120 A 400 mm	±10'		±15'																																																													
MAS DE 400 mm	±5'		±10'																																																													
<table border="1"> <thead> <tr> <th>ANGULAR</th> <th>FINO</th> <th>MEDIO</th> <th>GRUESO</th> </tr> </thead> <tbody> <tr> <td>MAS DE 10 A 50 mm</td> <td>±30'</td> <td></td> <td>±50'</td> </tr> <tr> <td>MAS DE 50 A 120 mm</td> <td>±20'</td> <td></td> <td>±25'</td> </tr> <tr> <td>MAS DE 120 A 400 mm</td> <td>±10'</td> <td></td> <td>±15'</td> </tr> <tr> <td>MAS DE 400 mm</td> <td>±5'</td> <td></td> <td>±10'</td> </tr> </tbody> </table>							ANGULAR	FINO	MEDIO	GRUESO	MAS DE 10 A 50 mm	±30'		±50'	MAS DE 50 A 120 mm	±20'		±25'	MAS DE 120 A 400 mm	±10'		±15'	MAS DE 400 mm	±5'		±10'	SUSTITUIDO POR:				<table border="1"> <thead> <tr> <th>COMUN A</th> <th>MODELO</th> <th>Ud.</th> <th>MODELO</th> <th>Ud.</th> <th>MODELO</th> <th>Ud.</th> <th>MODELO</th> <th>Ud.</th> <th>MODELO</th> </tr> </thead> <tbody> <tr> <td>BPL-4</td> <td>1</td> <td></td> <td></td> <td></td> <td></td> <td></td> <td></td> <td></td> <td></td> </tr> <tr> <td>BPC-4</td> <td>1</td> <td></td> <td></td> <td></td> <td></td> <td></td> <td></td> <td></td> <td></td> </tr> </tbody> </table>				COMUN A	MODELO	Ud.	MODELO	Ud.	MODELO	Ud.	MODELO	Ud.	MODELO	BPL-4	1									BPC-4	1								
ANGULAR	FINO	MEDIO	GRUESO																																																													
MAS DE 10 A 50 mm	±30'		±50'																																																													
MAS DE 50 A 120 mm	±20'		±25'																																																													
MAS DE 120 A 400 mm	±10'		±15'																																																													
MAS DE 400 mm	±5'		±10'																																																													
COMUN A	MODELO	Ud.	MODELO	Ud.	MODELO	Ud.	MODELO	Ud.	MODELO																																																							
BPL-4	1																																																															
BPC-4	1																																																															
<table border="1"> <thead> <tr> <th>LINEAL</th> <th>FINO</th> <th>MEDIO</th> <th>GRUESO</th> </tr> </thead> <tbody> <tr> <td>HASTA 3 mm</td> <td>±0,05</td> <td>±0,10</td> <td>±0,15</td> </tr> <tr> <td>MAS DE 3 A 6 mm</td> <td>±0,05</td> <td>±0,10</td> <td>±0,20</td> </tr> <tr> <td>MAS DE 6 A 30 mm</td> <td>±0,10</td> <td>±0,20</td> <td>±0,50</td> </tr> <tr> <td>MAS DE 30 A 120 mm</td> <td>±0,15</td> <td>±0,30</td> <td>±0,80</td> </tr> <tr> <td>MAS DE 120 A 400 mm</td> <td>±0,20</td> <td>±0,50</td> <td>±1,20</td> </tr> <tr> <td>MAS DE 400 A 1000 mm</td> <td>±0,30</td> <td>±0,80</td> <td>±2,00</td> </tr> <tr> <td>MAS DE 1000 A 2000 mm</td> <td>±0,50</td> <td>±1,20</td> <td>±3,00</td> </tr> </tbody> </table>							LINEAL	FINO	MEDIO	GRUESO	HASTA 3 mm	±0,05	±0,10	±0,15	MAS DE 3 A 6 mm	±0,05	±0,10	±0,20	MAS DE 6 A 30 mm	±0,10	±0,20	±0,50	MAS DE 30 A 120 mm	±0,15	±0,30	±0,80	MAS DE 120 A 400 mm	±0,20	±0,50	±1,20	MAS DE 400 A 1000 mm	±0,30	±0,80	±2,00	MAS DE 1000 A 2000 mm	±0,50	±1,20	±3,00	A4		Nombre		Fecha																					
LINEAL	FINO	MEDIO	GRUESO																																																													
HASTA 3 mm	±0,05	±0,10	±0,15																																																													
MAS DE 3 A 6 mm	±0,05	±0,10	±0,20																																																													
MAS DE 6 A 30 mm	±0,10	±0,20	±0,50																																																													
MAS DE 30 A 120 mm	±0,15	±0,30	±0,80																																																													
MAS DE 120 A 400 mm	±0,20	±0,50	±1,20																																																													
MAS DE 400 A 1000 mm	±0,30	±0,80	±2,00																																																													
MAS DE 1000 A 2000 mm	±0,50	±1,20	±3,00																																																													
Dibujado		G.CH		9-2-10																																																												
Modificado		VVM		20-01-17																																																												
Escala		1:15		BANDEJA FRIA TAPAS CRISTAL PLANO BPL- BPC -4						Código máquina: CODIGO																																																						