



CVE-10E CRISTAL ELEVABLE

VITRINA EXPOSITORA REFRIG. CVE-10E CRISTAL ELEVABLE/ SERVE
OVER COUNTER LIFTABLE GLASS



CVE-10E-20-RC-TF



LINEAL CVE-10E-20-RC-TF +
CVE-10E-20-RC-TF

CARACTERISTICAS GENERALES

- Cristal frontal templado y elevable.
- Estante de cristal intermedio, opcional
- Iluminación estándar: encimera superior led
- Reserva refrigerada con puertas, hueco 440x270 (excepto modelo neutro y sin reserva)
- Evaporador ventilado.
- Condensación ventilada, evaporación automática de serie
- Evaporación estática opcional

GENERAL FEATURES

- Toughened curved and liftable glass.
- Glass shelf non refrigerated, optional
- Refrigerated under storage with doors, 440x270 free (except for ambient models and without reservation)
- Ventilated evaporator
- Ventilated condensation and automatic defrost evaporation as standard
- Optional static evaporation

Características técnicas y constructivas sujetas a variación sin previo aviso, todas las fotos deben ser consideradas como una referencia

CVE-10E CRISTAL ELEVABLE

VITRINA EXPOSITORA REFRIG. CVE-10E CRISTAL ELEVABLE/ SERVE
OVER COUNTER LIFTABLE GLASS

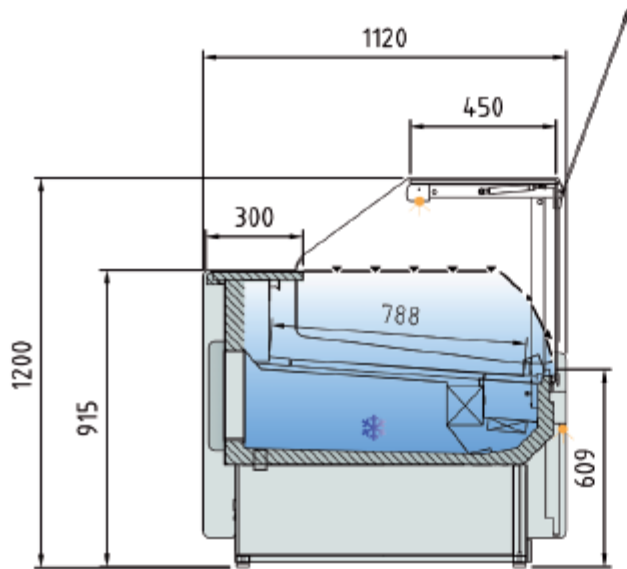

CVE-10E-RC-TF

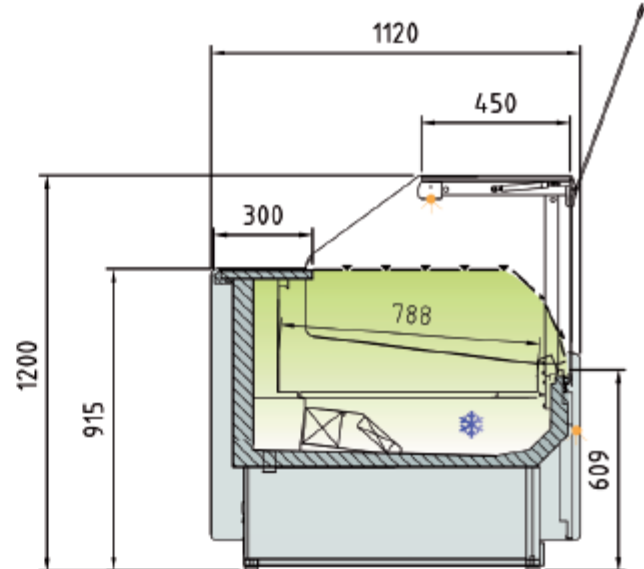

CVES-10E-RC-TF

Modelo Model Modèle	Largo Length Longueur (mm)	Superficie de exposición Display area Surface d'exposition (m ²)	Superficie total de exposición (TDA) Total display area (TDA) Surface totale de l'exposition (TDA) (m ²) (RR)	Cámara VE Storage VE Stockage VE (lts.)	Puertas Doors Portes (Uds)	Potencia frig. Frig. Power Puissance frig. (W)	Consumo Nominal Nominal power Consommation nominale (W)	Refrigerante Coolant Réfrigérant
CVE / CVES-10E-10-RC-TF	1025	0,80	0,91	293	1 / 0	565	851	R-290
CVE / CVES-10E-13-RC-TF	1265	1,00	1,13	369	2 / 0	572	912	R-290
CVE / CVES-10E-15-RC-TF	1505	1,21	1,36	444	2 / 0	781	1046	R-290
CVE / CVES-10E-20-RC-TF	1985	1,61	1,81	594	3 / 0	1098	1290	R-290
CVE / CVES-10E-25-RC-TF	2465	2,01	2,26	745	4 / 0	1284	1354	R-290
CVE / CVES-10E-30-RC-TF	2945	2,41	2,71	896	4 / 0	1284	1378	R-290

Características técnicas y constructivas sujetas a variación sin previo aviso, todas las fotos deben ser consideradas como una referencia

CORECO S.A. Ctra. Córdoba - Málaga Km. 80,800

Tlfs: +34 957 50 22 75 Fax: +34 957 51 42 98

14900 LUCENA (Córdoba), Spain

info@coreco.es

www.coreco.es