

DAW-200-NN

ARMARIO EXPOSITOR REFRIGERADO VINOS

CARACTERÍSTICAS

- Exterior en acero plastificado negro.
- Respaldo en chapa de acero galvanizado.
- Interior en aluminio plastificado negro.
- Puerta de cristal doble, con sistema de cierre automático y burlete magnético (permanece abierta al superar los 90° de apertura), con marco aluminio anodizado y doble cristal con tratamiento bajo-emisivo.
- Iluminación interior reforzada con doble tira de LEDs 3000K.
- Estantes en AISI-304 con frontal en madera, inclinables 20°.
- Cerradura con llave de serie.
- Reguladores de altura delanteros y rodillos en la parte trasera para facilitar el desplazamiento.
- Unidad condensadora ventilada.
- Evaporador sistema tiro forzado, con recubrimiento epoxi anticorrosión.
- Paro ventiladores tiro forzado al abrir la puerta.
- Evaporación automática del agua de descarche.
- Aislamiento de poliuretano inyectado, densidad 40 kg/m³, cero efectos ODP y GWP.
- Control digital de temperatura y humedad, descarches optimizados, alarma por puerta abierta y alta temperatura de condensación. Eficiente gestión del consumo de energía.



Largo (mm)	Fondo (mm)	Alto (mm)	Capacidad (L)	Potencia frigorífica (W)	Rango	Clase climática	Refrigerante
600	650	900	120	304	+2°C +18°C	4 (30°C 55%HR)	R290

Características técnicas y constructivas sujetas a variación sin previo aviso, todas las fotos deben ser consideradas como una referencia

DAW-200-NN

ARMARIO EXPOSITOR REFRIGERADO VINOS

Control de temperatura	Digital
Evaporador	Bloque aleteado epoxi
Condensador	Estático
Voltaje / Frecuencia	230V / 50Hz
Potencia nominal	201 W
Aislante térmico	Poliuretano, densidad 40 kg/m ³ , cero ODP y GWP
Agente espumante	HFO
Espesor aislante costado	50 mm
Exterior	Acero plastificado negro
Respaldo exterior	Acero galvanizado
Interior	Aluminio plastificado negro
Luz	Led
Número de estantes	2
Dimensiones estantes (W x D)	480 mm x 380 mm (2 Uds.)
Capacidad botellas	26

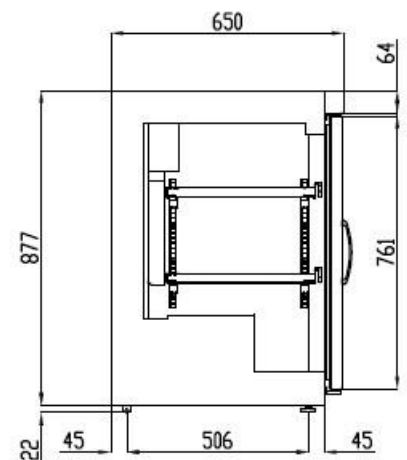
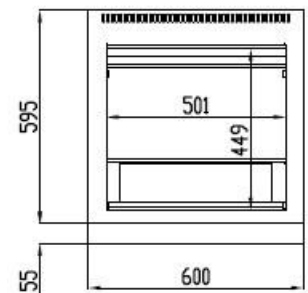
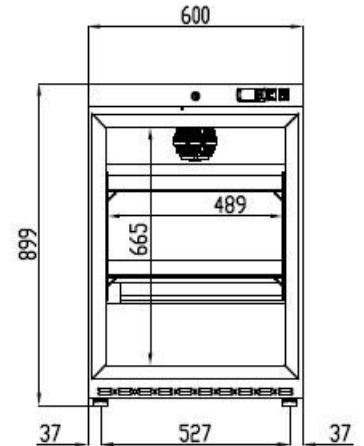

Características técnicas y constructivas sujetas a variación sin previo aviso, todas las fotos deben ser consideradas como una referencia



DAW-200-NN

REFRIGERATED WINE DISPLAY CABINET

FEATURES

- Black plastic coated exterior.
- Rear side in galvanized panel.
- Black plastic coated interior.
- Double glazed door with self closing system, blocked opening and magnetic gasket.
- 3000K double LED interior lighting.
- AISI-304 shelves with wooden front, tiltable 20°.
- Key lock as standard.
- Height adjusters at the front and rollers at the rear for ease of movement.
- Ventilated condensing unit.
- Evaporator forced draft system, with anti-corrosion epoxy coating.
- Forced draft fans stop when the door is opened.
- Automatic evaporation of defrost water.
- 40 Kg/m³ density polyurethane insulation, zero ODP and GWP.
- Digital temperature and humidity control, optimized defrost, open door alarm and high condensation temperature alarm. Efficient management of energy consumption.



Length (mm)	Depth (mm)	Height (mm)	Capacity (L)	Cooling power (W)	Range	Climatic class	Coolant
600	650	900	120	304	+2°C +18°C	4 (30°C 55%HR)	R290

We reserve the right to change specifications without prior notice, all photos must be considered as a reference

DAW-200-NN

REFRIGERATED WINE DISPLAY CABINET

Temperature control	Digital
Evaporator	Epoxy finned block
Condenser	Static
Voltage / Frequency	230V / 50Hz
Nominal power	201 W
Insulation material	Polyurethane, 40 kg/m ³ density, zero ODP and GWP
Foaming agent	HFO
Insulation thickness side	50 mm
Exterior	Black plastic coated
Exterior rear side	Galvanized steel
Interior	Black plastic coated
Lighting	Led
Number of shelves supplied	2
Shelves dimensions (W x D)	480 mm x 380 mm (2 Uds.)
Bottle capacity	26

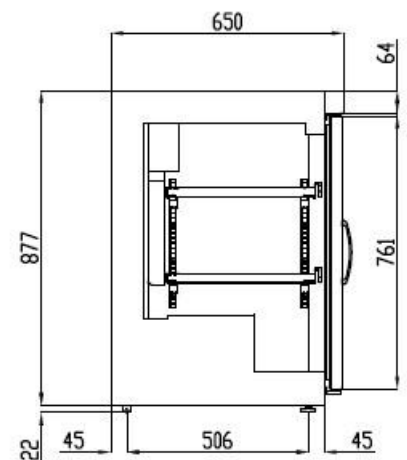
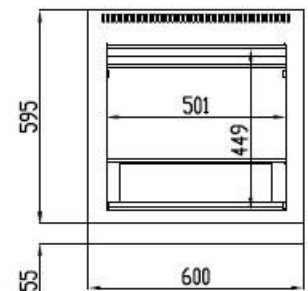
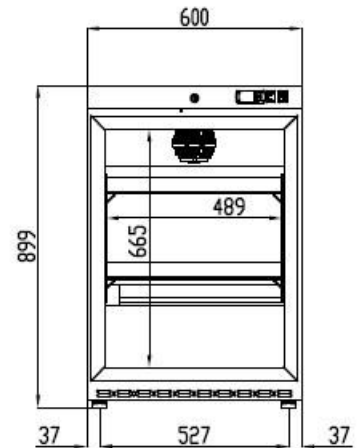

We reserve the right to change specifications without prior notice, all photos must be considered as a reference