

EI-1/4-225

EXPOSITOR INGREDIENTES FAST-FOOD GN

CARACTERÍSTICAS

- Exterior e interior en acero inoxidable.
- Cúpula de cristal.
- Capacidad para cubetas GN **(no incluidas)**.
- Apoyos regulables en altura.
- Luz de serie.
- Evaporador por placa fría.
- Aislamiento de poliuretano inyectado, densidad 40 kg/m³,cero efectos ODP and GWP.
- Control digital de temperatura, descarches optimizados, alarma por alta temperatura de condensación. Eficiente gestión del consumo de energía.



Largo (mm)	Fondo (mm)	Alto (mm)	Potencia frigorífica (W)	Rango	Clase climática	Refrigerante
2245	340	450	488	+2°C +8°C	4 (30°C 55%HR)	R-290

Características técnicas y constructivas sujetas a variación sin previo aviso, todas las fotos deben ser consideradas como una referencia

CORECO S.A. Ctra. Córdoba - Málaga Km. 80,800

Tlfs: +34 957 50 22 75 Fax: +34 957 51 42 98

14900 LUCENA (Córdoba), Spain

info@coreco.es

www.coreco.es

EI-1/4-225

EXPOSITOR INGREDIENTES FAST-FOOD GN

Control de temperatura	Digital
Evaporador	Serpentín
Condensador	Bloque aleteado
Voltaje / Frecuencia	230V / 50Hz
Potencia nominal	232 W
Aislante térmico	Poliuretano, densidad 40 kg/m ³ , cero ODP y GWP
Agente espumante	HFO
Espesor aislante costado	40 mm
Exterior	Acero inoxidable
Interior	Acero inoxidable
Luz	Sí
Número de huecos	10 GN 1/4

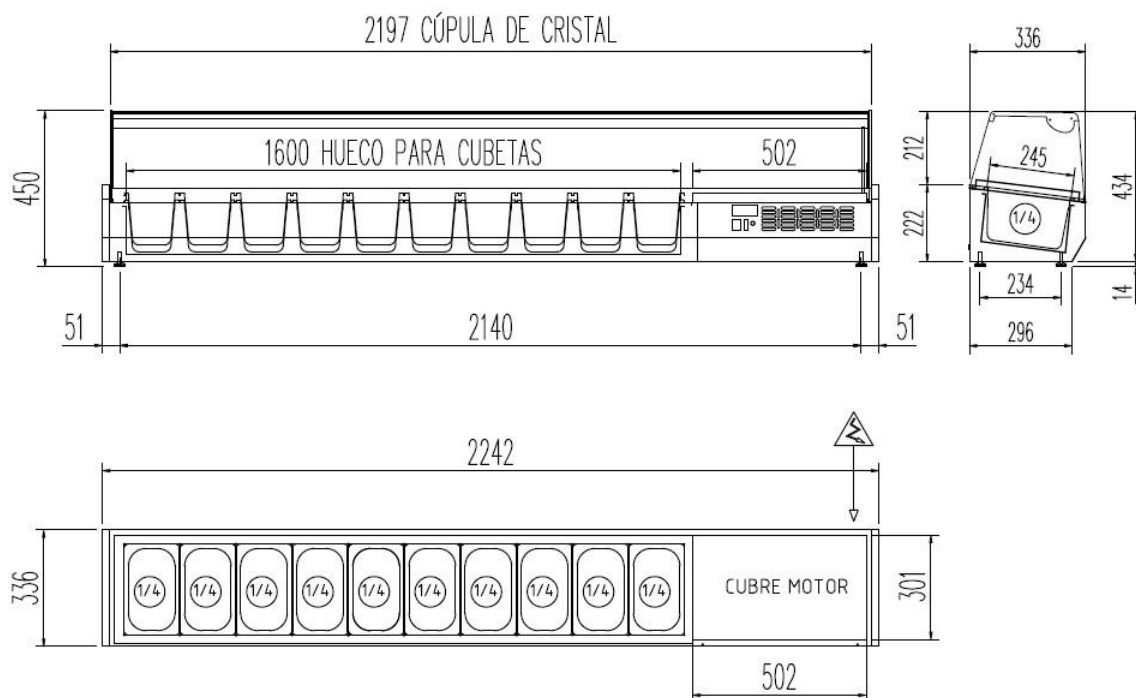

Características técnicas y constructivas sujetas a variación sin previo aviso, todas las fotos deben ser consideradas como una referencia

CORECO S.A. Ctra. Córdoba - Málaga Km. 80,800

Tlfs: +34 957 50 22 75 Fax: +34 957 51 42 98

14900 LUCENA (Córdoba), Spain

info@coreco.es

www.coreco.es

EI-1/4-225

FAST FOOD INGREDIENT DISPLAY GN

FEATURES

- Stainless steel exterior and interior.
- Glass dome.
- Capacity for GN containers (**not included**).
- Height-adjustable supports.
- Standard light.
- Cold plate evaporator.
- Injected polyurethane insulation, density 40 kg/m³, zero ODP and GWP effects.
- Digital temperature control, optimised defrosting, high condensation temperature alarm. Efficient energy consumption management.



Length (mm)	Depth (mm)	Height (mm)	Cooling capacity (W)	Range	Climate	Refrigerant
2245	340	450	488	+2°C +8°C	4 (30°C 55%RH)	R-290

Technical and construction specifications subject to change without prior notice. All photos should be considered for reference purposes only.

EI-1/4-225

FAST FOOD INGREDIENT DISPLAY GN

Temperature control	Digital
Evaporator	Coil
Condenser	Finned block
Voltage / Frequency	230V / 50Hz
Nominal power	232 W
Thermal insulation	Polyurethane, density 40 kg/m ³ , zero ODP and GWP
Foaming agent	HFO
Side insulation thickness	40 mm
Exterior	Stainless steel
Interior	Stainless steel
Light	Yes
Number of compartments	10 GN 1/4

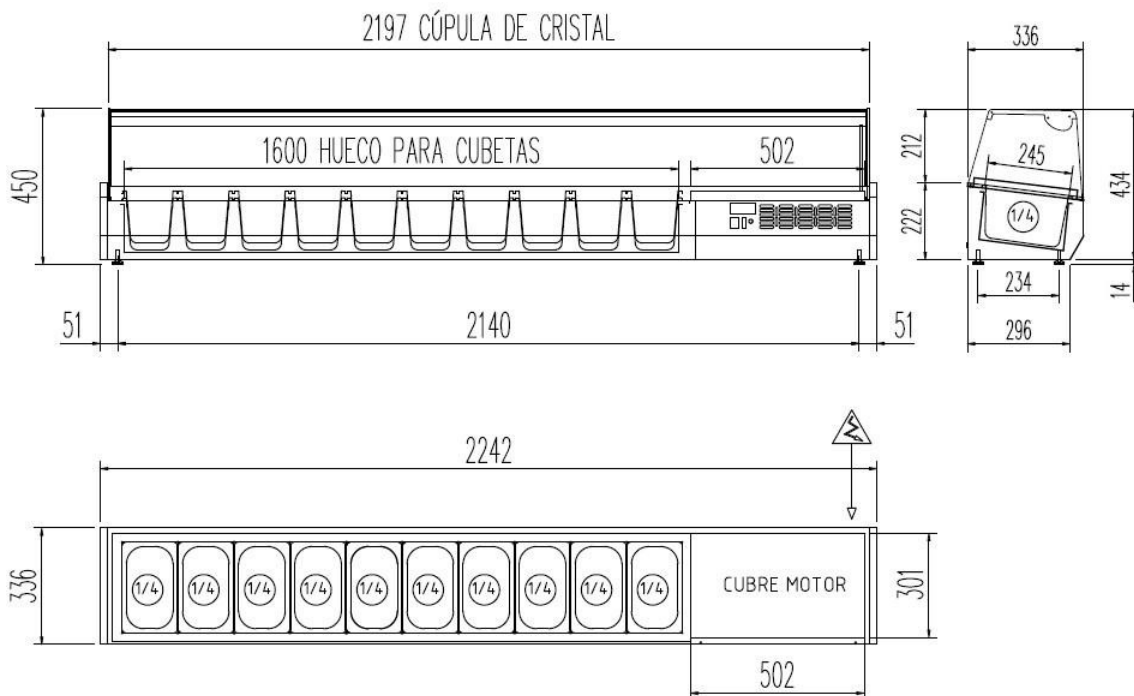

Technical and construction specifications subject to change without prior notice. All photos should be considered for reference purposes only.

CORECO S.A. Ctra. Córdoba - Málaga Km. 80,800

Tel: +34 957 502275 Fax: +34 957 5142 98

14900 LUCENA (Córdoba), Spain

info@coreco.es

www.coreco.es

EI-1/4-225

PRÉSENTOIR INGRÉDIENTS FAST-FOOD GN

CARACTÉRISTIQUES

- Extérieur et intérieur en acier inoxydable.
- Dôme en verre.
- Capacité pour bacs GN (**non inclus**).
- Supports réglables en hauteur.
- Éclairage de série.
- Évaporateur à plaque froide.
- Isolation en polyuréthane injecté, densité 40 kg/m³, zéro effet ODP et GWP.
- Contrôle numérique de la température, dégivrage optimisé, alarme en cas de température de condensation élevée. Gestion efficace de la consommation d'énergie.



Largeur (mm)	Profondeur (mm)	Hauteur (mm)	Puissance frigorifique (W)	Plage	Classe climatique	Réfrigérant
2245	340	450	488	+2 °C +8 °C	4 (30 °C 55 % HR)	R-290

Les caractéristiques techniques et de construction sont susceptibles d'être modifiées sans préavis. Toutes les photos doivent être considérées comme une référence.

CORECO S.A. Ctra. Córdoba - Málaga Km. 80,800 Tél. : +34957 502275 Fax : +34957 5142 98

14900 LUCENA (Córdoba), Espagne

info@coreco.es

www.coreco.es

EI-1/4-225

PRÉSENTOIR INGRÉDIENTS FAST-FOOD GN

Contrôle de la température	Numérique
Évaporateur	Serpentin
Condenseur	Bloc à ailettes
Tension / Fréquence	230 V / 50 Hz
Puissance nominale	232 W
Isolant thermique	Polyuréthane, densité 40 kg/m ³ , zéro ODP et GWP
Agent moussant	HFO
Épaisseur de l'isolant sur les côtés	40 mm
Extérieur	Acier inoxydable
Intérieur	Acier inoxydable
Éclairage	Oui
Nombre d'emplacements	10 GN 1/4

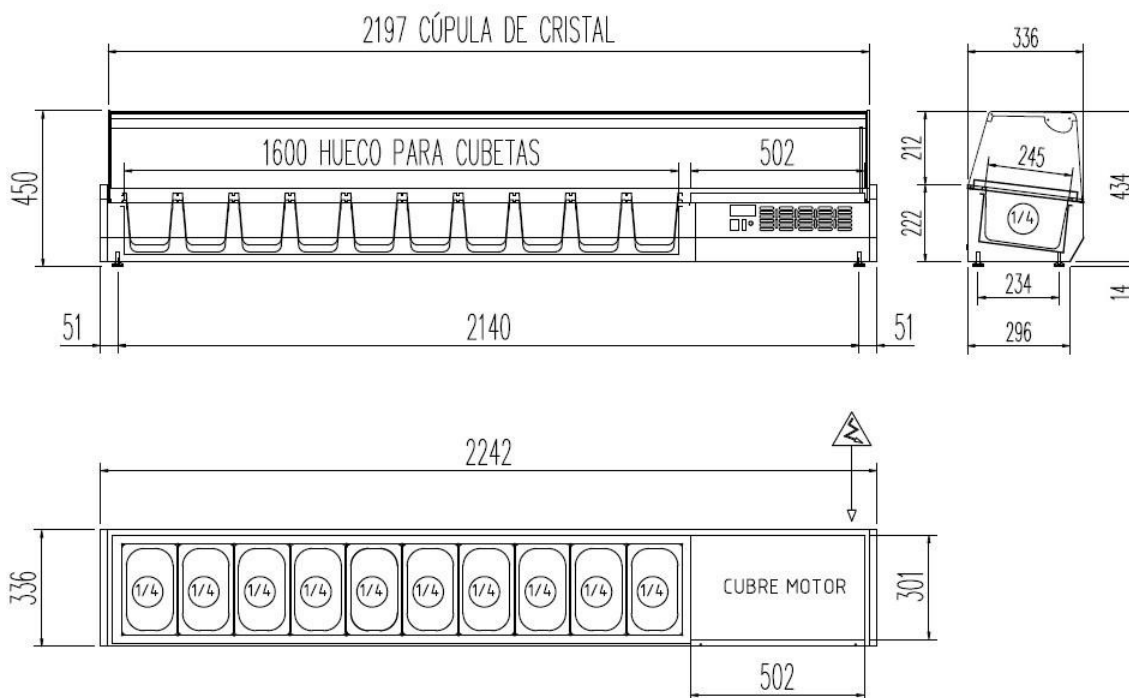

Les caractéristiques techniques et de construction sont susceptibles d'être modifiées sans préavis. Toutes les photos doivent être considérées comme une référence.

CORECO S.A. Ctra. Córdoba - Málaga Km. 80,800 Tél. : +34957 502275 Fax : +34957 5142 98

14900 LUCENA (Córdoba), Espagne

info@coreco.es

www.coreco.es