



MR80-160



MR80-210



MR80-265

El precio incluye vitrina de ingredientes - *Topping unit included in price*  
 Cubetas GN NO incluidas en el precio - *GN containers NOT included in price*  
 ver página 387- see page 387

mod.	rango range °C	largo length (mm)	alto height (mm)	fondo depth (mm)	estantes shelves	pares guías slides sets	cajas neutras neutral containers	cajas refrigeradas refrigerated containers	volumen capacity (L)	voltaje voltage	refrigerante refrigerant	potencia frig. frig. power W	potencia power W
MR80-160	0°C +8°C	1565	850	800	0	8	3	3	362	230V-50Hz	R134a*	178	211
											R290	502	235
MR80-210	0°C +8°C	2090	850	800	0	13	3	3	562	230V-50Hz	R134a*	245	249
											R290	502	238
MR80-265	0°C +8°C	2615	850	800	0	18	3	3	761	230V-50Hz	R134a*	304	289
											R290	845	355

\*opcional - optional

Características técnicas y constructivas sujetas a variación sin previo aviso.

- Exterior en acero inox AISI-304, excepto el respaldo
- Interior en acero inox AISI-304, con aristas curvas
- Puertas de apertura reversible, con sistema de cierre automático y burlete magnético (permanece abierta al superar los 90° de apertura)
- Contrapuerta inox embutida
- Encimera de granito, con peto trasero y laterales de 180 mm
- Interior con guías de acero inox, regulables en altura para parrillas, bandejas o contenedores 60x40x7 (4 en dotación)
- Cajón neutro con 3 contenedores 60x40x7 en dotación
- Pies en tubo de acero inox ajustables en altura 135 - 210 mm
- Unidad condensadora ventilada y extraíble
- Evaporador sistema tiro forzado, con recubrimiento epoxi anticorrosión
- Evaporación automática del agua de descarche
- Aislamiento de poliuretano inyectado, densidad 40 Kg/m<sup>3</sup>, cero efectos ODP y GWP
- Control digital de temperatura, descarches optimizados, alarma por alta temperatura de condensación. Eficiente gestión del consumo de energía
- Expositor de ingredientes independiente, capacidad GN 1/4, incluido
- Temperatura de trabajo e 32°C ambiente

We reserve the right to change specifications without prior notice.

- AISI-304 stainless steel exterior, rear side galvanized panel
- AISI-304 stainless steel interior, stamped bottom and rounded corners
- Doors with self closing system, blocked opening, magnetic gasket and possibility of changing the opening sense
- Inner side of doors by stamped steel
- Granite working surface with 180 mm upstands
- interior with stainless steel slides, height adjustable, capacity for 60x40 shelves, trays or containers (4 as standard)
- Neutral drawer with three 60x40x7 containers as standard
- AISI -304 adjustable legs, 135 to 210 mm
- Removable and fan assisted condenser unit
- Fan assisted evaporator, with epoxi anticorrosion coating.
- Automatic evaporation of defrost water
- 40 Kg/m<sup>3</sup> density polyurethane insulation, zero ODP and GWP
- Digital temperature control, optimized defrost, high-temperature condensation alarm. Efficient management of energy consumption
- GN 1/4 topping unit, included
- Operating temperature 32°C ambient

FAST & COOL FOOD

**OPCIONES**

OPCIONES	OPTIONS
parrilla 60x40	60x40 shelf
cajón plástico 60x40x7	60x40x7 plastic container
cajón plástico 60x40x12	60x40x12 plastic container
cerradura puerta inox	solid door lock
motor lado izquierdo	left side engine
set 4 ruedas	4 castors set
set 6 ruedas	6 castors set
registrador de alarmas HACCP	HACCP alarm recorder
respaldo inox	stainless steel rear side
230v 60Hz / 115v 60Hz	230v 60Hz / 115v 60Hz
Sin expositor de ingredientes	Without topping unit
cambio R290 por R134a	R290 to R134a



Mesa fría PIZZA cajón neutro  
 PIZZA counter with neutral drawer

2

all photos must be considered as a reference - fotografías no contractuales

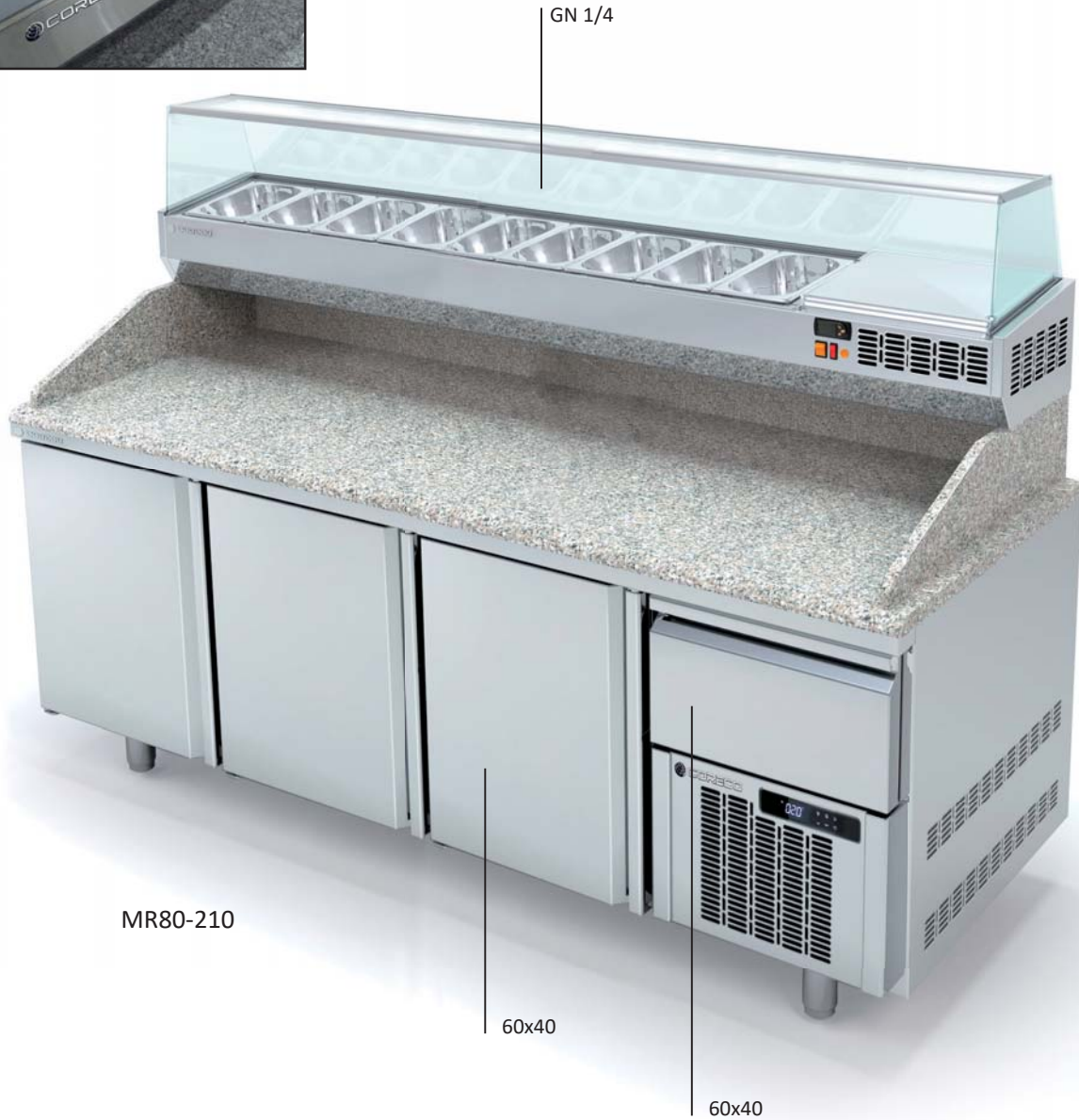

MR80-210

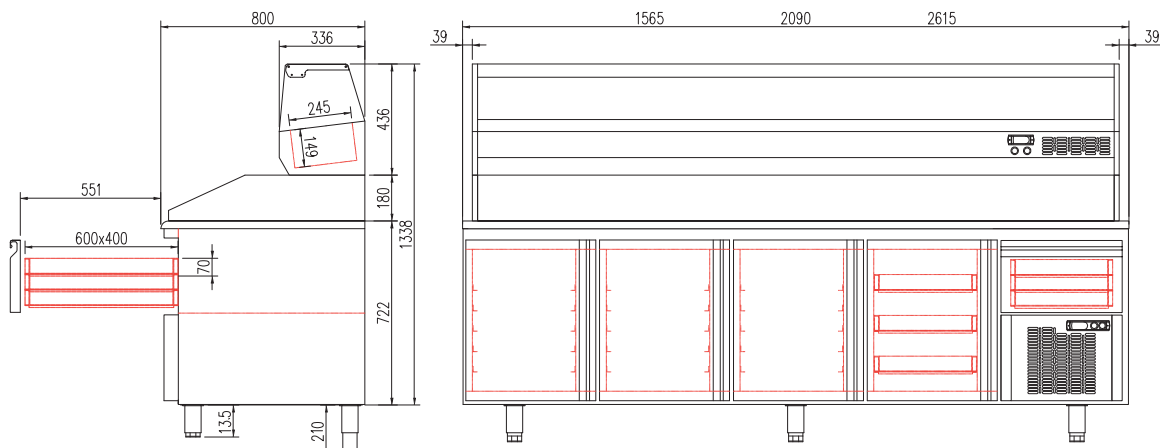

FAST & cool  
 FOOD 2